

**EDUCATIONAL WALL CHART
PHYSICS, MICRO PROCESSOR,
POWER ELECTRONIC & FIBER OPTICS
OMEGA TYPE CPY, CMP, CPE & CFO**

Omega Educational Wall Charts are based on basics as well as advanced concept on Microprocessors (CMP), Power Electronics (CPE), Fibre Optics (CFO) and Physics (CPY). These charts are available in size of 24 x 36 Inches and lot of 10 charts as a set.

Wall Charts - Physics (CPY-001 to CPY-010)

- | | |
|------------------------------------|---------|
| 01 Introduction To Physics | CPY-001 |
| 02 Waves And Oscillations | CPY-002 |
| 03 Optics - I | CPY-003 |
| 04 Optics - II | CPY-004 |
| 05 Electro-Magnetic Induction - I | CPY-005 |
| 06 Electro-Magnetic Induction - II | CPY-006 |
| 07 Modern Physics | CPY-007 |
| 08 Electrostatics | CPY-008 |
| 09 Mechanics | CPY-009 |
| 10 Semiconductor Devices | CPY-010 |

Wall Charts - Microprocessor (CMP-001 to CMP-010)

- | | |
|-------------------------------------------------------------|---------|
| 01 8085a : 8 – Bit Microprocessor | CMP-001 |
| 02 8086 16 - Bit Microprocessor | CMP-002 |
| 03 8255a : Programmable Peripheral Interface | CMP-003 |
| 04 8251a : Programmable Communication Interface | CMP-004 |
| 05 8155/8156/2048 – Bit Static Ram With I/o Ports And Timer | CMP-005 |
| 06 8259a : Programmable Interrupt Controller | CMP-006 |
| 07 8257 – Dma Controller | CMP-007 |
| 08 Z-80 Cpu Control Processing Unit | CMP-008 |
| 09 Microprocessor Memory Architecture | CMP-009 |
| 10 80386 – 32 Bit Microprocessor | CMP-010 |

Wall Charts - Power Electronics(CPE-001 to CPE-010)

- | | |
|-----------------------------------------|---------|
| 01 Power Electronics At A Glance | CPE-001 |
| 02 Family Of Thyristors | CPE-002 |
| 03 Application Of Various Power Devices | CPE-003 |
| 04 Rectifying Circuits | CPE-004 |
| 05 Scr & Mct | CPE-005 |
| 06 Mosfet & Igbt | CPE-006 |
| 07 Diac & Triac | CPE-007 |
| 08 Ujt & Gto | CPE-008 |
| 09 Power Supplies (smps) | CPE-009 |
| 10 Choppers & Inverters | CPE-010 |

Wall Charts - Fibre Optics (CFO-001 to CFO-010)

- | | |
|-------------------------------------------------|---------|
| 01 Introduction And Application Of Fibre Optics | CFO-001 |
| 02 Fibre Cables | CFO-002 |
| 03 Connectors And Couplers | CFO-003 |
| 04 Fibre Optics Sensor | CFO-004 |
| 05 Fibre Optics Light Sources | CFO-005 |
| 06 Repeaters, Regenerators, And Amplifiers | CFO-006 |
| 07 Splicing | CFO-007 |
| 08 Measurements Of Optic Fibres - 1 | CFO-008 |
| 09 Measurements Of Optic Fibres - 2 | CFO-009 |
| 10 Application And Future Development | CFO-010 |

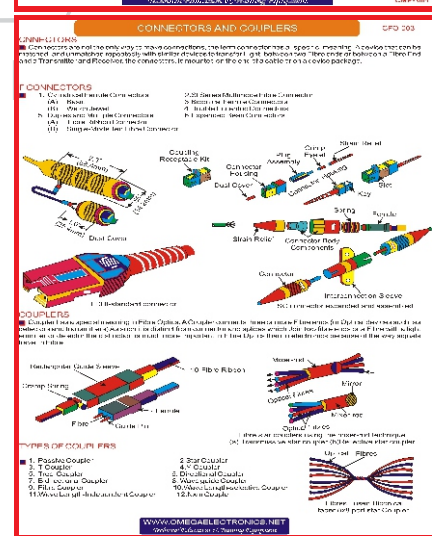
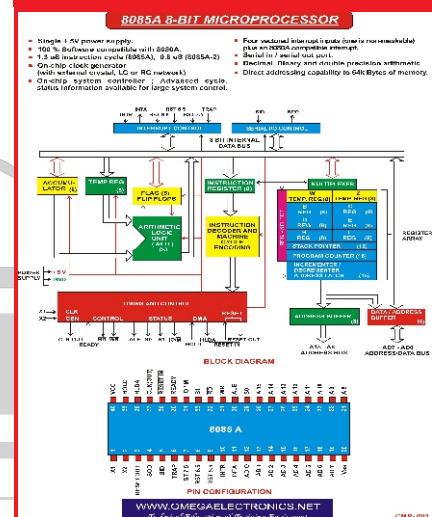
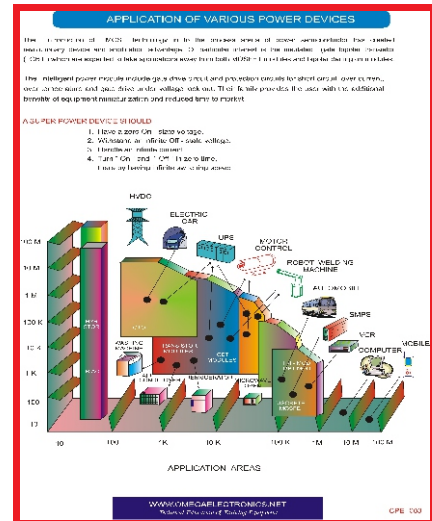

We are committed to the continuous development of our products, and therefore reserve the right to amend specifications without prior notice.

OMEGA ELECTRONICS

Works:
28E & F, Malviya Industrial Area,
Jaipur-302 017 (INDIA)
Phone: 0141-2751559

E-mail : info@omegaelectronics.net
: omegajipur62@gmail.com

www.omegaelectronics.net

Marketing Division:
B-28, Fateh Singh Scheme, Opp. Rajputana
Palace Sheraton, Jaipur-302006 (INDIA)
Phone : 091-141-2375647, 2379223